

# CRT Science Review #1

## Physical Science: Matter



**Standard: Matter**– Matter has various states with unique properties that can be used as the basis for organization. The relationship between the properties of matter and its structure is an essential component of study in the physical sciences. The understanding of matter and its properties leads to practical applications, such as the capability to liberate elements from ore, create new drugs, manipulate the structure of genes and synthesize polymers.

### Indicators & Item Specifications:

**P.8.A.1 Students know particles are arranged differently in solids, liquids, and gases of the same substance. E/S**

- Identify substances as solids, liquids and gases.
- Describe the different states of matter using the terms shape and volume.
- Given a diagram, recognize the arrangement of particles in solids, liquids and gases.
- Describe the different states of matter as having more or less molecular kinetic energy.

**P.8.A.2 Students know elements can be arranged in the periodic table which shows repeating patterns that group elements with similar properties. E/S**

- Understand that some elements can have similar properties (e.g., magnetism, conductivity, density, and solubility) based on their position in the periodic table.
- Predict properties of different elements based on their arrangements in groups and periods on the periodic table.

**P.8.A.3 Students know methods for separating mixtures based on the properties of the components. E/S**

- Understand the terms solvent, solute, and solution.
- Identify properties of matter including: magnetism, density, conductivity, solubility.
- Identify properties of matter that can be used to separate mixtures (e.g., filtering, chromatography, settling, chemical reaction, and evaporation).

**P.8.A.4 Students know atoms often combine to form molecules, and that compounds form when two or more different kinds of atoms chemically bond. E/S**

- Understand physical and chemical properties.
- Understand physical and chemical changes and identify evidence of chemical changes (e.g., releasing heat, absorbing heat, and producing gas).
- Given a chemical formula, identify the number and type of atoms in molecule.
- Understand that chemical reactions can result in a pH change (acids, bases, and neutralizations).

**P.8.A.5 Students know mass is conserved in physical and chemical changes. E/S**

- Identify that the total mass remains the same in a chemical change (i.e., the number and type of atoms in the reactants equals the number and type of atoms in the products).
- Know matter is conserved in a physical change.

**P.8.A.6 Students know matter is made up of tiny particles called atoms. E/S**

- Identify that atoms are the smallest units of elements.

**P.8.A.7 Students know the characteristics of electrons, protons, and neutrons. E/S**

- Know the structure of the atom.
- Know the electrical charges of electrons, protons, and neutrons.
- Know the relative size of electrons, protons, and neutrons compared to the overall atom.

**P.8.A.8 Students know substances containing only one kind of atom are elements which cannot be broken into smaller pieces by normal laboratory processes. E/S**

- Identify that elements contain only one type of atom.

### *Sample Multiple Choice CRT-Style Questions Related to Matter*

1. What is the smallest unit of an element that still has the properties of that element?
  - A. A molecule
  - B. An electron
  - C. A compound
  - D. An atom
2. Pure water is neutral and has a pH of 7. When lemon juice is added to water the pH will become lower than 7 and turns litmus paper red. Lemon juice is
  - A. a salt.
  - B. an acid.
  - C. a base.
  - D. neutral.

3. A student has two unknown substances that must be classified into states of matter. Which properties would be used?
- Mass and volume
  - Shape and volume
  - Weight and shape
  - Density and weight

4. Which of the following describes the differences between solids and liquids?
- Both have a definite shape, but only solids have a definite volume.
  - Both have a definite volume, but only liquids have a definite shape.
  - Solids have a definite volume and shape, but liquids only have a definite volume.
  - Liquids have a definite volume and shape, but solids only have a definite shape.

5. According to the Law of Conservation of Mass, the number of iron atoms needed to complete the following reaction is

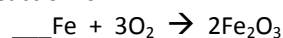

- 1
  - 2
  - 3
  - 4
6. Use a periodic table to answer the following question. Which group of elements would be expected to have similar properties?
- Oxygen, sulfur, selenium
  - Nitrogen, oxygen, fluorine
  - Sodium, magnesium, potassium
  - Neon, sodium, potassium
7. How many electrons are in a neutral atom with an atomic number of 12?
- 4
  - 6
  - 12
  - 24
8. The mass number of an element is the total number of protons and neutrons located in the nucleus. If carbon has an atomic number of 6 and a mass number of 12, how many neutrons does it contain?
- 0
  - 6
  - 12
  - 18
9. When salt dissolves in water, the water is the
- solvent.
  - solute.
  - solubility.
  - solution.

10. Use the drawing below to answer the next question.

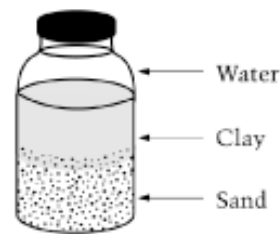

(From: [http://nationsreportcard.gov/science\\_2005/s0116.asp](http://nationsreportcard.gov/science_2005/s0116.asp))

A student put sand, clay, and water into a bottle and shook the bottle. Then, the contents of the bottle were allowed to settle. After two hours, the bottle looked like the drawing above. What can the student conclude?

- The water layer is denser than the layers of clay and sand.
  - The layer of clay is denser than the layers of sand and the water.
  - The layer of sand is denser than the water layer and the layer of clay.
  - The water layer, layer of clay, and layer of sand are all the same density.
11. Analyze the model of an atom below.
- 
- Which of the above numbers indicates the orbit of the electrons that could bond with electrons of other atoms to make molecules?
- I
  - II
  - III
  - IV
12. Which of the following is a chemical property of matter?
- Melting
  - Magnetism
  - Flammability
  - Density
13. Which of the following pairs of compounds contain the same number of atoms, but different kinds of atoms?
- $\text{CO}_2$  and  $\text{CaCl}_2$ .
  - $\text{CO}_2$  and  $\text{CO}$ .
  - $\text{MgCO}_3$  and  $2\text{CaCO}_3$ .
  - $\text{C}_4\text{H}_{10}$  and  $\text{C}_5\text{H}_{12}$ .

14. When sulfuric acid,  $\text{H}_2\text{SO}_4$ , is broken down into separate elements, how many **different** atoms result?
- Two
  - Three
  - Six
  - Seven

15. An oxygen atom has 8 protons, 8 neutrons and 8 electrons. If the oxygen atom gains two electrons to form an oxygen ion, what will be the magnitude and sign of the charge?
- 2
  - +2
  - 8
  - +8

16. Atoms of an element contain only one type of atom because they each contain the same number of
- protons.
  - electrons.
  - neutrons.
  - nucleons.
17. A student is given a sample of an unknown liquid to test in a laboratory. Which of the following physical properties will be most useful to determine if the liquid is water?
- The color of the liquid.
  - The mass of the liquid.
  - The volume of the liquid.
  - The boiling point of the liquid.

18. The diagram below shows a balance used to measure a burning candle in a sealed glass ball before and after the burning is complete.

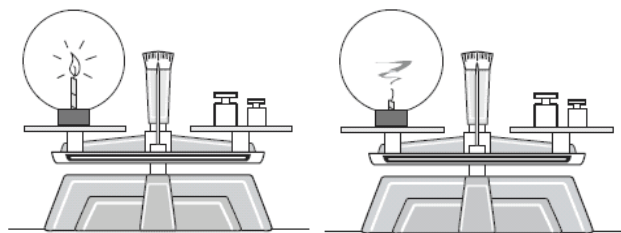

Before

After

(From <http://www.doe.mass.edu/mcas/>)

As the candle burns, the size of the candle decreases, but the reading on the balance does not change. Which of the following is demonstrated by this experiment?

- The total mass of the system is constant.
- Energy is converted to mass when the candle is burned.
- Smoke particles have more mass than the molecules of candle wax.
- Kinetic energy is converted to potential energy when the candle is burned.

### Sample Constructed Response Questions Related to Matter

19. A demonstration is performed using this cylinder (shown to the right), a small rubber ball, and three liquids. The liquids are syrup (density of 1.8 g/mL), vegetable oil (density of 0.8 g/mL), and water (density of 1.0 g/mL), poured into the cylinder.

- Draw and label the arrangement of these three liquids within the cylinder. Justify the reasons for your arrangement of the liquids.
- The small rubber ball, with a density of 0.9 g/mL, is dropped into the cylinder you have drawn. Describe and draw where the ball will stop, and justify your answer.



20. A student's teacher gave him a piece of iron and asked him to determine the physical and chemical properties of the metal. The teacher wants the properties organized as either physical or chemical. The student's observations are in the table below.

Physical and Chemical Properties of Iron
Conducts electricity
Reacts with acid
Reacts with oxygen in the air to form rust.
Attracts to a magnet

- Create a data table to identify the properties as physical or chemical properties.
- Explain why you categorized **each** property as either a physical or chemical property.

## CRT Science Review #1 Key Physical Science: Matter



**Standard: Matter**– Matter has various states with unique properties that can be used as basis for organization. The relationship between the properties of matter and its structure is an essential component of study in the physical sciences. The understanding of matter and its properties leads to practical applications, such as the capability to liberate elements from ore, create new drugs, manipulate the structure of genes and synthesize polymers.

### Answer Key

- |                   |                    |
|-------------------|--------------------|
| 1. D, DOK Level 1 | 10. C, DOK Level 2 |
| 2. B, DOK Level 1 | 11. A, DOK Level 1 |
| 3. B, DOK Level 1 | 12. C, DOK Level 1 |
| 4. C, DOK Level 1 | 13. A, DOK Level 2 |
| 5. D, DOK Level 2 | 14. B, DOK Level 1 |
| 6. A, DOK Level 2 | 15. A, DOK Level 2 |
| 7. C, DOK Level 1 | 16. A, DOK Level 1 |
| 8. B, DOK Level 2 | 17. D, DOK Level 1 |
| 9. A, DOK Level 1 | 18. A, DOK Level 2 |

### Constructed Response Answers

19. DOK Level 3

<b>3 Points</b>	<p><i>Response addresses all parts of the question clearly and correctly.</i></p> <p>A. The student correctly draws and labels the liquids in the cylinder. Based upon the densities of the liquids, the syrup would be on the bottom (1.8 g/ml), the water would be in the middle (1.0 g/ml), and the vegetable oil would be on the top (0.8 g/ml).</p> <p>B. The ball would float at the top of the vegetable oil and the bottom of the water because its density at 0.9 g/ml is between the densities of the oil and water.</p>
<b>2 Points</b>	<i>Response addresses all parts of the question and includes only minor errors.</i>
<b>1 Point</b>	<i>Response does not address all parts of the question.</i>
<b>0 Points</b>	<i>Response is totally incorrect or no response provided.</i>

20. DOK Level 2

<b>3 Points</b>	<p><i>Response addresses all parts of the question clearly and correctly.</i></p> <p>A. The student correctly draws a data table.</p> <table border="1" style="margin-left: auto; margin-right: auto;"> <thead> <tr> <th style="text-align: center;">Physical Properties</th> <th style="text-align: center;">Chemical Properties</th> </tr> </thead> <tbody> <tr> <td style="text-align: center;">Conducts Electricity</td> <td style="text-align: center;">Reacts with Acid</td> </tr> <tr> <td style="text-align: center;">Attracts to magnet</td> <td style="text-align: center;">Reacts with oxygen in the air to form rust.</td> </tr> </tbody> </table> <p>B. Student provides correct explanation for categorizing each characteristic.</p>	Physical Properties	Chemical Properties	Conducts Electricity	Reacts with Acid	Attracts to magnet	Reacts with oxygen in the air to form rust.
Physical Properties	Chemical Properties						
Conducts Electricity	Reacts with Acid						
Attracts to magnet	Reacts with oxygen in the air to form rust.						
<b>2 Points</b>	<i>Response addresses all parts of the question and includes only minor errors.</i>						
<b>1 Point</b>	<i>Response does not address all parts of the question.</i>						
<b>0 Points</b>	<i>Response is totally incorrect or no response provided.</i>						

## CRT Science Review #2

### Physical Science: Force and Motion



**Standard: Force and Motion – The laws of motion are used to describe the effects of forces on the movement of objects.**

#### Indicators & Item Specifications:

**P.8.B.1 Students know the effects of balanced and unbalanced forces on an object's motion. E/S**

- Know how motion is defined, described, and measured.
- Explain how balanced and unbalanced forces are related to the motion of an object.
- Explain the relationship between acceleration, force, and mass.
- Given a scenario, predict outcomes based on application of Newton's 3 laws of motion.
- Explain how the amount of friction between objects can be changed.
- Explain how an increase or decrease in friction can be beneficial.
- Create and/or interpret motion graphs.

**P.8.B.2 Students know electric currents can produce magnetic forces and magnets can cause electric currents. E/S**

- Understand the relationship between electric currents and magnetic forces.

**P.8.B.3 Students know every object exerts gravitational force on every other object, and the magnitude of this force depends on the mass of the objects and their distance from one another. I/S**

- Understand the relationship between mass and weight.
- Explain the relationship between gravity and the motion of falling objects.
- Identify and describe qualitatively the relationship between gravitational force, mass, and distance (Universal Law of Gravitation).

#### *Sample Multiple Choice CRT-Style Questions Related to Force and Motion*

1. A horse is walking at a constant speed of 2 m/s. How far will the horse travel in thirty minutes?

- A. 15 m
- B. 60 m
- C. 1800 m
- D. 3600 m

2. A cart with a mass of 100 kg accelerates when 10 N is applied. If the mass is doubled, how much force is required to maintain the same acceleration.

- A. 10 N
- B. 20 N
- C. 100 N
- D. 200 N

3. A girl riding on a skateboard at 3 m/s suddenly hits the curb. The girl will fall

- A. backward with a speed greater than 3 m/s.
- B. forward with a speed greater than 3 m/s.
- C. backward at a speed equal to 3 m/s.
- D. forward at a speed equal to 3 m/s.

4. How does decreasing the number of turns in the coil of wire affect the strength of the magnetic field of the electromagnet?

- A. It does not change.
- B. It becomes stronger.
- C. It becomes weaker.
- D. It disappears.

5. Use the diagram to answer the following question. The arrows below show forces acting on an object.

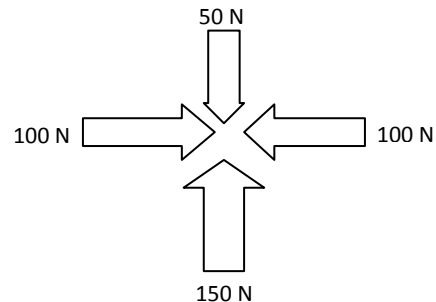

What is the net force on the object and in what direction would the object move?

- A. 100 N to the right
- B. 100 N to the left
- C. 100 N upward
- D. 150 N upward

6. If the Earth were twice as massive, then the gravitational force between it and the sun would be

- A. four times as great.
- B. the same.
- C. twice as great.
- D. half as great.

7. Below is a **distance vs. time** graph showing the action of a person over time. Use this graph to answer the following question.

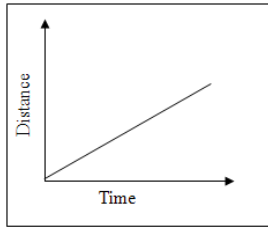

Which of the following statements is the **best** description of the person's action? The person is walking

- A. up a large hill.
  - B. faster as time increases.
  - C. at a slowing speed up a hill.
  - D. at a constant speed.
8. Below is a **velocity vs. time** graph showing the movement of a train over time. Use this graph to answer the following question.

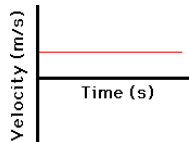

Which of the following statements is the **best** description of the train's motion? The train is

- A. not moving in any direction.
- B. continuously accelerating.
- C. moving with a constant velocity.
- D. accelerating slowly.

**Sample Constructed Response Question Related to Force and Motion**

11. The data in the table below records the weight of an object at five equal distances from Earth. Location 1 is taken at Earth's surface.

Location (#)	Distance (Earth Radii)	Force (Newton)
1	r	500 N
2	2r	125 N
3	3r	56 N
4	4r	31 N
5	5r	20 N

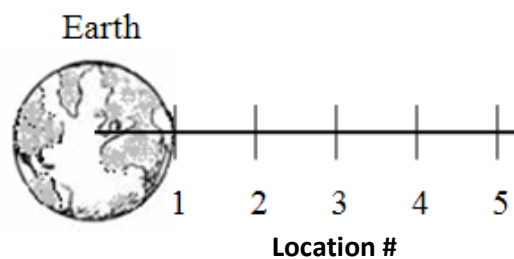

- A. What is happening to the mass of the object as it is taken from Location 1 to Location 5?
- B. Using graph paper, plot **Force versus Location** for the five locations from the data table. Label the x and y-axis with the appropriate labels and units, and provide a graph title.
- C. Using your graph, explain what is happening to the weight of the object as the object is taken from Location 1 to Location 5.

9. In each diagram below, the mass of two objects is labeled. These masses are separated by a radius.

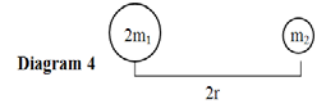
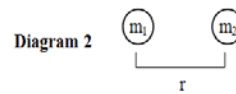
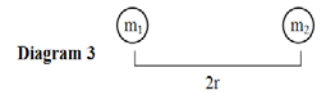
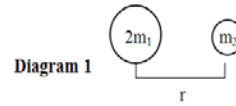

Which diagram would produce the **greatest** gravitational force between the two objects?

- A. Diagram 1
  - B. Diagram 2
  - C. Diagram 3
  - D. Diagram 4
10. The distance between two charges is represented by "d". What diagram shows the **greatest** attractive force between the two charged objects?

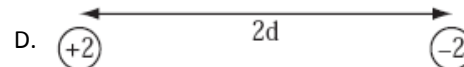
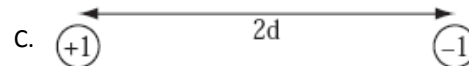
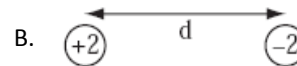
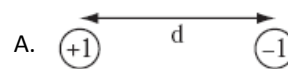

## CRT Science Review #2 Key

### Physical Science: Force and Motion



**Standard: Force and Motion – The laws of motion are used to describe the effects of forces on the movement of objects.**

**Answer Key**

1. D, DOK Level 2
2. B, DOK Level 2
3. D, DOK Level 2
4. C, DOK Level 1
5. C, DOK Level 2
6. C, DOK Level 1
7. D, DOK Level 2
8. C, DOK Level 2
9. A, DOK Level 2
10. B, DOK Level 2

**Constructed Response Answer**

11. DOK Level 3

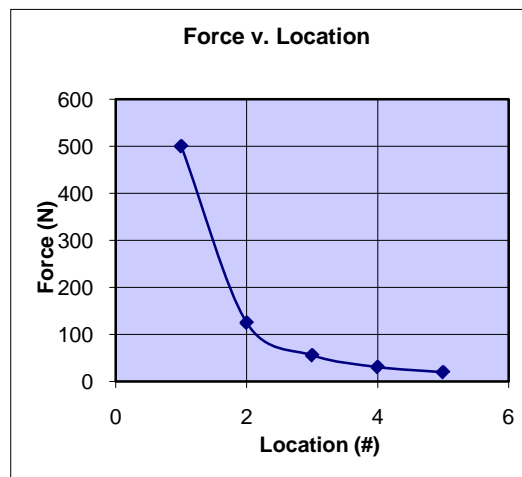

<b>3 points</b>	<p><i>Response addresses all parts of the question clearly and correctly.</i></p> <p>Mass is a property of matter that does not depend upon location in a gravitational field. Mass of the object remains constant. Student graph shape matches the key with graph title, and correct labels for both x-axis and y-axis. Weight decreases rapidly with distance as shown in the downward sloping graph. Weight depends on location. As distance increases, weight decreases. The strength of the gravitational field decreases with distance resulting in less weight.</p>
<b>2 points</b>	<i>Response addresses all parts of the question and includes only minor errors.</i>
<b>1 point</b>	<i>Response does not address all parts of the question.</i>
<b>0 points</b>	<i>Response is totally incorrect or no response provided.</i>

Visit RPDP's Middle School TIPS website for additional sample CRT questions: [http://rpd.net/sciencetips\\_v3/](http://rpd.net/sciencetips_v3/)

## CRT Science Review #3

### Physical Science: Energy



**Standard: Energy – The total energy of the universe is constant. All events involve the transfer of energy in one form or another. In all energy transfers, the overall effect is that energy is spread out uniformly.**

#### Indicators & Item Specifications:

##### **P.8.C.1 Students know visible light is a narrow band within the electromagnetic spectrum. I/S**

- Know visible light is a small segment of the entire electromagnetic spectrum.
- Recognize and identify the properties of light (e.g., color, brightness, wavelength, frequency, reflection, refraction, and diffraction).
- Understand the relationship between the electromagnetic radiation emitted by an object and the object's temperature.

##### **P.8.C.2 Students know vibrations (e.g., sounds, earthquakes) move at different speeds in different materials, have different wavelengths, and set up wave-like disturbances that spread away from the source uniformly. E/S**

- Understand that sound is produced and carried by molecules.
- Identify and describe characteristics of waves: wavelength, frequency, amplitude and speed.
- Recognize that waves transfer energy differently in different materials.
- Identify the causes and effects of the Doppler Effect.
- Understand the relationship between velocity, wavelength, and frequency.
- Understand the difference between transverse waves and longitudinal waves.

##### **P.8.C.3 Students know physical, chemical, and nuclear changes involve a transfer of energy. E/S**

- Recognize that in physical, chemical, and nuclear changes energy is transformed.

##### **P.8.C.4 Students know energy cannot be created or destroyed, in a chemical or physical reaction, but only changed from one form to another. E/S**

- Identify and describe differences between kinetic and potential energy.
- Describe common energy transformations (e.g., chemical to motion, radiant to chemical, electrical to thermal, electrical to radiant).

##### **P.8.C.5 Students know heat energy flows from warmer materials or regions to cooler ones through conduction, convection, and radiation. E/S**

- Explain convection, conduction, and radiation using terms of heat transfer.
- Given a scenario involving heat transfer, recognize convection, conduction, and radiation.
- Compare different materials and their ability to transfer heat.
- Understand the properties of conductors and insulators.

##### **P.8.C.6 Students know electrical circuits provide a means of transferring electrical energy to produce heat, light, sound, and chemical changes. I/S**

- Recognize and diagram parallel and series circuits.
- Identify the different parts of parallel and series circuits.
- Describe the function of each part of the circuit.
- Understand the function of conductors, resistors, and insulators in circuits.
- Describe the path electric current takes in parallel and series circuits.
- Recognize that electricity is the transfer of energy through moving electrical charges (in both current and static electricity).
- Know like charges repel and opposite charges attract (flow of electricity).
- Know some mediums allow electricity to pass through them more readily than others.
- Know electrical energy can be transformed into other types of energy (e.g., magnetic, heat, light, sound, and mechanical) and those other types can be transformed back into electrical energy.

#### ***Sample Multiple Choice CRT-Style Questions Related to Energy***

1. What part of the electromagnetic spectrum can be directly observed by humans?
  - A. Visible light
  - B. Radio waves
  - C. Ultraviolet light
  - D. Gamma rays
2. The frequency of a wave can be calculated by
  - A. multiplying the velocity times the wavelength.
  - B. dividing the speed by the wavelength.
  - C. multiplying the amplitude by the wavelength.
  - D. dividing the frequency by the velocity.



3. Which of the following is a transfer of chemical energy to thermal energy?
  - A. A hairdryer is turned on to dry a girl's hair.
  - B. A boy eats an apple, which regulates his body temperature.
  - C. An atom is split to increase the temperature of water
  - D. An ice cube is placed in warm soup and melts.
4. If one part of a solid object is at a higher temperature and another part of the same object is at a lower temperature, the heat is transferred within the object through the process of
  - A. conduction.
  - B. convection.
  - C. insulation.
  - D. radiation.
5. There are two bright stars in a constellation. One of the stars appears blue. The other star appears red. Which of the following is the **best** explanation for the difference in the stars' color?
  - A. The blue star must have a smaller mass compared to the red star.
  - B. The blue star must have a larger size compared to the red star
  - C. The blue star must have a greater surface temperature compared to the red star.
  - D. The blue star must be moving toward the Earth and the red star away from Earth.

6. Use the diagram below to answer the following question.

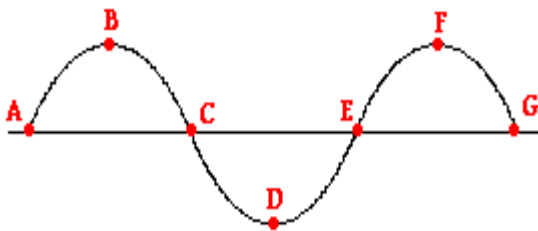

Which interval represents one full wavelength?

- A. Point A to Point C
  - B. Point B to Point D
  - C. Point A to Point G
  - D. Point C to Point G
7. If you place three ice cubes in a glass of water at room temperature, which of the following will occur?
    - A. Energy from the water will transfer to the ice cubes, causing the ice to melt.
    - B. Cold from the ice cubes will transfer to the water, causing the water to freeze.
    - C. Energy will transfer equally between the ice cubes and the water, causing no change.
    - D. Cold is transferred from the ice/water mixture to the air, causing the air to cool.

8. The diagram below shows sound waves traveling away from a vibrating bell. Use the diagram below to answer the following question.

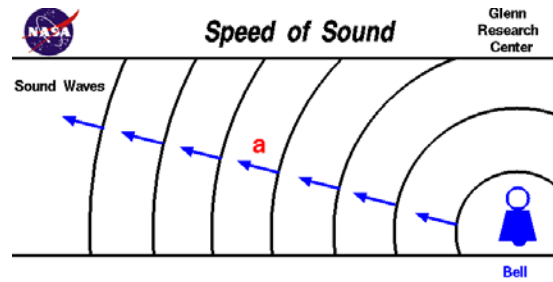

(From <http://www.grc.nasa.gov/WWW/K-12/airplane/sound.html>)

Which of the following factors would impact the speed of the waves?

- A. The direction of the wave as it vibrates away from the bell.
  - B. How hard the bell was struck to initiate the vibrations.
  - C. Temperature and medium through which the sound is traveling.
  - D. Whether the bell was made of steel or some other type of metal.
9. The reason a fire truck's siren sounds higher in pitch as it approaches you is because the truck pushes the sound waves together so that the sound wavelengths in front of the truck get shorter. This causes
    - A. frequency to increase which increases the pitch.
    - B. velocity to decrease which increases the frequency.
    - C. frequency to decrease which decreases the pitch.
    - D. wavelengths to elongate increasing the pitch.
  10. A pot is made out of aluminum, but its handle is plastic. Why are these materials used in this way?
    - A. Aluminum is a conductor of heat, which allows the pot's temperature to increase rapidly, while plastic is a heat insulator, preventing rapid heat transfer and keeping the handle cool.
    - B. Plastic is a heat conductor, which allows heat to move quickly out of the handle, keeping the handle cool, while aluminum is a heat insulator that holds the heat within the pot.
    - C. Both aluminum and plastic are heat conductors that allow heat to be transferred throughout the pot.
    - D. Both aluminum and plastic are heat insulators that keep the heat contained within the pot.
  11. Which of the following waves in the electromagnetic spectrum has the longest wavelength?
    - A. Gamma waves
    - B. Radio waves
    - C. Infrared waves
    - D. Visible light waves

12. Use the figure below to answer the next question.

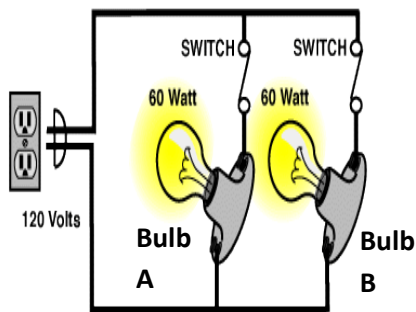

When Bulb B burns out, Bulb A

- A. stays the same.
- B. gets brighter
- C. gets dimmer
- D. stops working.

13. A circuit diagram is shown below.

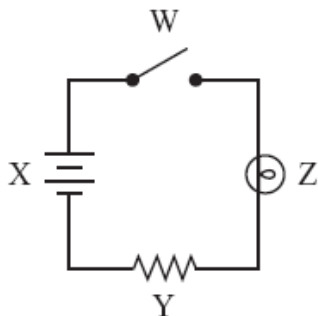

(From <http://www.doe.mass.edu/mcas/>)

Which component in the diagram converts chemical energy into electrical energy?

- A. Component W
- B. Component X
- C. Component Y
- D. Component Z

**Sample Constructed Response Questions Related to Energy**

16. Sound is a form of energy that is transmitted through vibrations.

- A. Describe how sound waves are affected by their frequency and the medium through which the sound wave passes.
- B. A science fiction film shows an explosion in space that is heard by the space travelers on board a spaceship. Critique the correctness of this portrayal providing evidence for your argument.

17. The illustration shows a container of water on an electric hot plate. Point A represents the point closest to the heat source and point B is near the top of the container. The water in the container is at room temperature before the hot plate is turned on.

- A. Describe the differences in the average motion of the water molecules at point A and at point B shortly after the hot plate is turned on.
- B. The water is heated until a thermometer placed in the center of the container reaches 100°C. Compare the average motion of the water molecules at points A and B at this temperature and explain your answer.
- C. The hot plate is then turned off. Describe the average motion of the molecules at points A and B after several hours.

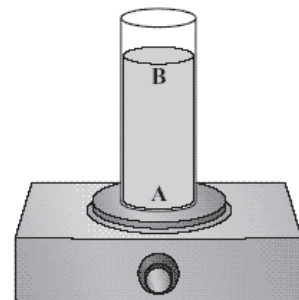

14. Which wave requires a medium for transmission?

- A. Light
- B. Radio
- C. Infrared
- D. Sound

15. The diagram below shows the path of a moving pendulum swinging from a fixed point called a fulcrum.

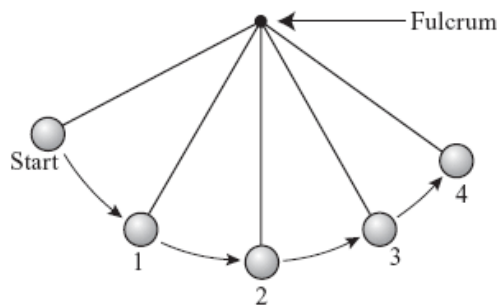

(From <http://www.doe.mass.edu/mcas/>)

At which two numbered positions is the **potential energy** of the pendulum most likely the same?

- A. Position 1 and Position 3
- B. Position 1 and Position 4
- C. Position 2 and Position 3
- D. Position 2 and Position 4

## CRT Science Review #3 Key Physical Science: Energy



**Standard: Energy – The total energy of the universe is constant. All events involve the transfer of energy in one form or another. In all energy transfers, the overall effect is that energy is spread out uniformly.**

### Answer Key

- |                   |                    |
|-------------------|--------------------|
| 1. A, DOK Level 1 | 9. A, DOK Level 2  |
| 2. B, DOK Level 1 | 10. A, DOK Level 2 |
| 3. B, DOK Level 2 | 11. B, DOK Level 1 |
| 4. A, DOK Level 1 | 12. B, DOK Level 2 |
| 5. C, DOK Level 1 | 13. B, DOK Level 1 |
| 6. D, DOK Level 1 | 14. D, DOK Level 1 |
| 7. A, DOK Level 2 | 15. A, DOK Level 2 |
| 8. C, DOK Level 2 |                    |

### Constructed Response Answers

16. DOK Level 3

<b>3 points</b>	<p><i>Response addresses all parts of the question clearly and correctly.</i></p> <p>A. Student response indicates an understanding that frequency is a measure of the regularity of passing sound waves and directly relates to the pitch of the sound, where a greater frequency results in a higher pitch. Student response also indicates sound is a mechanical wave, sound can only travel through a medium, and sound travels fastest through solids, then liquids, then gases.</p> <p>B. Sound is not transmitted through the vacuum of outer space. A student example might include bell ringer in a vacuum and observed lack of sound or a similar example.</p>
<b>2 points</b>	<i>Response addresses all parts of the question and includes only minor errors.</i>
<b>1 point</b>	<i>Response does not address all parts of the question.</i>
<b>0 point</b>	<i>Response is totally incorrect or no response provided.</i>

17. DOK Level 3

<b>3 points</b>	<p><i>Response addresses all parts of the question clearly and correctly.</i></p> <p>A. Student states a relationship between increased temperature and increased kinetic energy of the water molecules. When the hot plate is turned on, the water molecules are moving faster at Point A than Point B.</p> <p>B. The water molecules throughout the heater container are the same temperature and the molecules are moving at the same rate.</p> <p>C. Several hours after the heat source is turned off, the water molecules will move slower than they were before. Without a heat source, the temperature will be uniform and the molecules at Point A and Point B will move at the same rate.</p>
<b>2 points</b>	<i>Response addresses all parts of the question and includes only minor errors.</i>
<b>1 point</b>	<i>Response does not address all parts of the question.</i>
<b>0 point</b>	<i>Response is totally incorrect or no response provided.</i>